

**B.Tech. Civil (Construction Management) /
B.Tech. Civil (Water Resources Engineering)**

Term-End Examination

December, 2010

ET-105(A) : PHYSICS

Time : 3 hours

Maximum Marks : 70

Note : All questions are compulsory. Symbols have their usual meanings. Use of calculator is permitted.

1. Attempt *any five* of the following :- **5x4=20**

- (a) A bullet of mass 5g is travelling with a speed of 100 m/s. It hits a wall. Its speed decreases uniformly as it travels in the wall. It comes to rest after travelling 5 cm. Compute the average force exerted on the wall.
- (b) A solid sphere rolls without slipping down an inclined plane from a point at height h from the ground. If it started from rest, find its velocity on reaching the ground.
- (c) In a double slit interference experiment the distance between the aperture and the screen is 1.5 m. The wavelength of the source of light is 600 nm. The whole apparatus is kept in a medium of refractive index $4/3$. If the spacing between fringes is 1 mm, what is the slit separation.

- (d) A 12 V battery drives current in the following circuit. If a current of 1.2 A is desired in the arm AB, find R. The key is kept open.

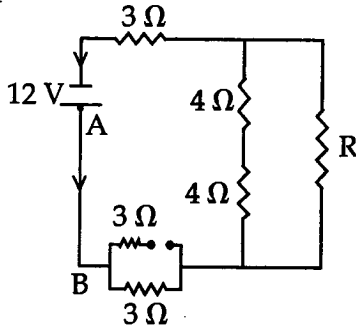

- (e) A particle of mass 3.3×10^{-15} kg and charge $4e$ is desired to be at rest under gravity. Find the magnitude and direction of the required electric field.
- (f) A magnetic field is given by :

$$\vec{B} = \frac{-y \hat{i} + x \hat{j}}{(x^2 + y^2)} \cdot \frac{\mu_0 i}{2\pi}$$

Verify that $\nabla \cdot \vec{B} = 0$

- (g) A 24 keV alpha particle is projected at 30° to a uniform magnetic field $\vec{B} = 0.05$ T. Calculate the radius of the helical path.

- (h) 8 drops of mercury of radius 0.8 mm each carry a charge of 90×10^{-12} C. They coalesce to form a single spherical drop. Calculate the capacitance of the new drop.

2. Attempt *any two* of the following :- 2x5=10

- (a) State Newton's laws of motion. Discuss if the first law can be considered a special case of the second law. Derive the relation between \vec{F} and \vec{a} .
- (b) Distinguish an elastic collision from an inelastic collision. Two rigid balls of equal masses and radii undergo an elastic collision with an impact parameter b . One of them is at rest before collision. If the speed of the incoming ball is V_0 , find the expressions for the velocities of the balls after collision.
- (c) Show that the orbit of a planet round the Sun is an ellipse. Derive expression for the total mechanical energy of the planet. What happens if this quantity is zero or positive?

3. Attempt *any two* of the following :- 2x5=10

- (a) Show that the kinetic energy of a system of particles can be written as the kinetic energy associated with the motion of the centre of mass and the kinetic energy of the particles relative to the centre of mass. A shell of mass m moving through air explodes and splits into two fragments of masses $m/3$ and $2m/3$. If explosion provides an additional energy E to the fragments, calculate the relative velocities of the fragments after explosion.
- (b) Explain why finite angular displacement is not a vector quantity and infinitesimal rotation has the character of a vector. Show that the acceleration of a rigid body rotating about an axis fixed in space is given by

$$\vec{a} = \vec{\alpha} \times \vec{r} + \vec{\omega} \times (\vec{\omega} \times \vec{r})$$

- (c) A rigid body of mass m and moment of inertia I oscillates freely in a vertical plane about a horizontal axis. Derive an expression for its time period. Is there any other point about which it has the same time period ?

4. Attempt *any two* of the following : 2x5=10

- (a) Get expressions for the width and intensity of fringes in a double slit experiment. Discuss how reflection from the lens of a camera are reduced.

- (b) Derive the equation of motion of a simple pendulum. Discuss how good the approximation $\sin\theta \approx \theta$ is in this context. Get the expression for the time period from the solution of the equation. What happens to a pendulum clock when the length of the pendulum decreases ?
- (c) Distinguish light waves from the sound waves. Derive the equation governing the propagation of sound waves under adiabatic conditions. Does the velocity of sound depend on the amount of moisture in the air ?

5. Attempt *any two* of the following : 2x5=10

- (a) Define electric field. Explain how the fields due to two sources can be superimposed. Get an expression for the field at a point produced by n charges located at different positions. The field due to a line charge at a distance of 100 cm is 100 N/C. What is the field at 20 cm ?
- (b) State 'Gauss' theorem. Derive the electric field due to a uniformly charged sphere. Show by a sketch how the field due to a spherical distribution of charges varies with distance from the centre of the distribution.

- (c) Derive an expression for the capacitance of a cylindrical capacitor. Find the equivalent capacitance of the network of capacitors shown below :

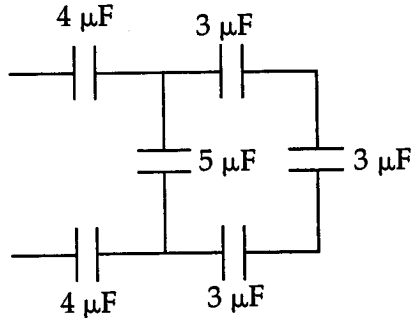

6. Attempt *any two* of the following : 2x5=10
- (a) Explain the meaning of the line integral of vector field and illustrate it by an example. State Ampere's law and establish it.
- (b) Discuss the flow of current in an L – C circuit. Is it possible to have a circuit with zero resistance ? Discuss the case when the L – C circuit contains a finite resistance.
- (c) Show that \vec{E} and \vec{B} associated with an electromagnetic wave are perpendicular to each other and both are perpendicular to the direction of propagation of the wave. Describe a setup to generate electromagnetic waves.

Constants

$$\frac{1}{4\pi\epsilon_0} = 9.0 \times 10^9 \text{ Nm}^2\text{C}^{-2}$$

$$\mu_0 = 4\pi \times 10^{-7} \text{ Hm}^{-1}$$

$$\text{Mass of } \alpha \text{ particle} = 6.4 \times 10^{-27} \text{ kg}$$

$$\text{Charge of } \alpha \text{ particle} = 3.2 \times 10^{-19} \text{ C}$$

$$\text{Mass of a proton} = 1.67 \times 10^{-27} \text{ kg}$$

$$\text{Charge of proton} = 1.6 \times 10^{-19} \text{ C}$$

$$g = 9.8 \text{ m/s}^2$$
