

BACHELOR OF ARCHITECTURE (BARCH)

Term-End Examination

December, 2013

BAR-053 : ESTIMATING AND COSTING

Time : 3 hours

Maximum Marks : 70

Note : Solve any five questions, all questions carrying equal marks.

1. What do you understand by the terms "Depreciation" and "Valuation" ? Discuss in detail. When a building gets dismantled completely, how is its value calculated. **9+5=14**

2. (a) (i) How is PWD Schedule of rates framed? **3**

(ii) How will you fix the rate of payment for a one - (ONE BR.TH.WALL)brick thick (in 1:6. cement-sand mortar) FIRST -class compound wall. Explain. **4**

- (b) How is the quantity and cost estimate of plumbing and electric fittings in a building prepared ? Discuss. **7**

3.

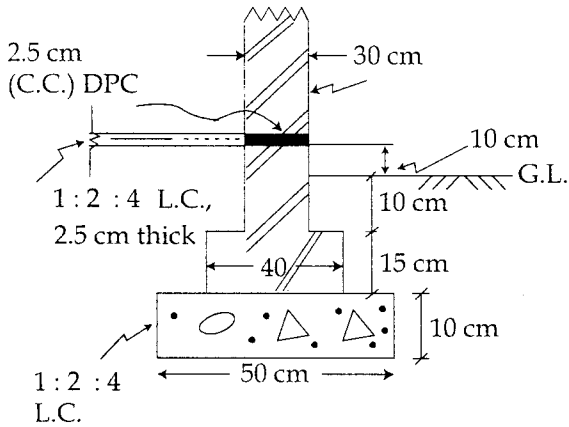
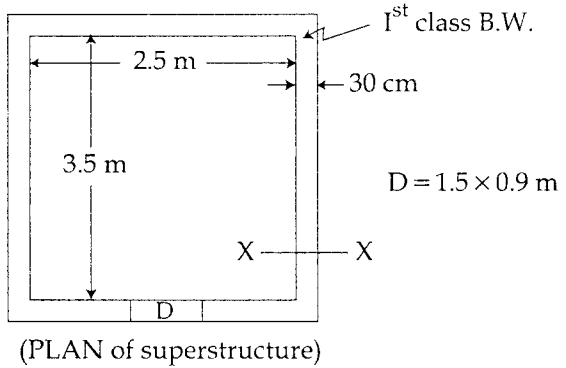

Given the plan of superstructure and section of a room estimate the following items:

- | | | |
|-----|--|---|
| (a) | L.C. (1:2:4) used in the foundation of the room , item-wise. | 3 |
| (b) | 1st class brick work in substructure | 5 |
| | (i) Upto G.L | 2 |
| | (ii) G.L.to DPC | 1 |
| | (iii) DPC | 2 |
| | (iv) Excavation of earth | 1 |
| | (v) Superstructure upto 3m height above D.P.C. | 1 |

4. Work out the rate analysis for the following items of work:
- (a) 1st class B.W. in 1:4 cement mortar in ground floor, and 1st floor. 4
 - (b) 1:2:4 R.C.C. roof slab. 3
 - (c) 1x2 m batten door (wooden) with 3 piece frame (chowk-at), assuming suitable data wherever needed. 7
5. (a) Explain what do you understand by specifications for a given item of work. 1
- (b) Write the detailed specifications for cement concrete flooring. 3
- (c) Give the units of measurement for the following: 10
- (i) Barbed wire fencing
 - (ii) On Boundary wall 2.5cm thick R.C.C.
On roof slab
 - (iii) Wall tiling
 - (iv) Lintels over doors and windows
 - (v) Sanitary fixtures
 - (vi) Kota stone in dado
 - (vii) Parapet around the roof slab
 - (viii) Plastering
 - (ix) Painting
 - (x) Polishing floor marble stones

6. Discuss the following terms at length:
- (a) Muster roll 5
 - (b) Work-charge establishment 3
 - (c) Administrative approval, and technical sanction 3
 - (d) Establishment charges, and suspense account 3
7. (a) What is an abstract of cost, and its importance ? 4
- (b) How do you fill a measurement book ? 10
8. Write short notes on **any three** of the following : 14
- (a) Type of contract
 - (b) Tender notice
 - (c) Importance and types of detailed drawing
 - (d) Issue rates
-