

ASSIGNMENT BOOKLET

Post Graduate Diploma in Applied Statistics

(Specialisations in Industrial Statistics/Biostatistics)

MST-001 to MSTE-004

(Valid from 1st January 2025 to 31stDecember, 2025)

It is compulsory to submit the assignments before filling the Examination Form. Candidates should submit the latest assignments for the courses for which they filled the examination form. Only Work books/Lab Record Books are needed to be submitted for the Lab Courses.



**School of Sciences
Indira Gandhi National Open University
Maidan Garhi, New Delhi-110068
(2025)**

Dear Student,

Please read the information on assignments in the Programme Guide that we have sent you after your enrolment. A weightage of 30%, as you are aware, has been earmarked for continuous evaluation, **which would consist of one tutor-marked assignment** for this course. The assignments for the theory courses MST-001 to MSTE-004 have been given in this booklet.

Instructions for Formatting Your Assignments

Before attempting the assignment, please read the following instructions carefully:

- 1) On top of the first page of your answer sheet, please write the details exactly in the following format:

ENROLLMENT NO :

NAME :

ADDRESS :

.....

.....

PROGRAMME CODE:

COURSE CODE:

COURSE TITLE:

STUDY CENTRE: DATE:

PLEASE FOLLOW THE ABOVE FORMAT STRICTLY TO FACILITATE EVALUATION AND TO AVOID DELAY.

- 2) Use only foolscap size writing paper (but not of very thin variety) for writing your answers.
- 3) Leave 4 cm margin on the left, top and bottom of your answer sheet.
- 4) Your answers should be precise.
- 5) This assignment is to be submitted at the Study Centre.

We strongly suggest that you should retain a copy of your answer sheets.

- 6) This assignment is valid from January 1st, 2025 up to December 31, 2025.
- 7) The latest assignments should be submitted by the candidate.
- 8) **You cannot fill the Exam Form for this course** till you have submitted this assignment. So solve it and **submit it to your study centre at the earliest.** If you wish to appear in the **TEE, June 2025**, you should submit your TMAs by **March 31, 2025**. Similarly, If you wish to appear in the **TEE, December 2025**, you should submit your TMAs by **September 30, 2025**.

We wish you good luck.

TUTOR MARKED ASSIGNMENT

MST-001: Foundation in Mathematics and Statistics

Course Code: MST-001

Assignment Code: MST-001/TMA/2025

Maximum Marks: 100

Note: All questions are compulsory. Answer in your own words.

1. State whether the following statements are **True** or **False**. Give reason in support of your answer: (5×2=10)

(a) Between any two different rational numbers there is another rational number.

(b)

$$\int_{-1000}^{1000} (x^{1000} - x^{999} + x^{998} - x^{997} + \dots + x - 1) dx = 0$$

(c) 210 is 51st term of the sequence 10, 15, 20, 25, ...

(d)

$$\begin{vmatrix} a & x & b+c & c \\ b & x & c+a & a \\ c & x & a+b & b \end{vmatrix} = 0$$

(e) The range of the data shown in the following frequency distribution is 350.

Classes	200-250	250-300	300-350	350-400	400-450	450-500	500-550
Frequencies	0	7	3	8	4	0	0

2. (a) A carpenter was hired to build 192 window frames. The first day he made five frames and each day thereafter he made two more frames than he made the day before. How many days he will take to finish his job? (4)

(b) Set having values $\overline{4916253649}^{\cdot}$ is countable. (3)

(c) How many words each of three vowels and two consonants can be formed from the letters of the words INVOLUTE? (3)

3. (a) Express 700.1400.2100.2800.3500.42000 in terms of factorial.

(b) How many different signals are possible with 5 blue, 4 red, 3 white and 2 green flags by using all at a time in a queue?

(c) If in a hall there are 10 randomly selected students then how many numbers of ways are there such that all of them have different birthday. Assume that all of them have their birthday in non-leap years. (2+4+4)

4. Discuss the continuity and differentiability of the following function at $x = 2/3$: (5+5)

$$f(x) = \begin{cases} x - \frac{2}{3} & x \geq 3 \\ 0 & x < 3 \end{cases}$$

5. Evaluate the following integrals: (5+5)

(i) $\int (10x^4 + 3\sqrt{8x^5 + 3x^5}) dx$

(ii) $\int \frac{1}{(x-5)(x+4)} dx$

6. Find values of x, y and z given that

$$5x + y + z = 36$$

$$x + y + z = 6$$

$$10x + 2y + 2z = 72$$

You are bound to use the matrix techniques to solve the given equations. (10)

7. (a) Write flow charts of Cramer rule and matrix method. (10)
- (b) Write whether the following data are discrete or continuous. Give reason in support of your answer. (5×2=10)
- i) Number of children in a family in a colony of 100 families.
 - ii) Number of pages in each of the 50 books having some mistake.
 - iii) Height of students of IGNOU who enrolled in 2021.
 - iv) Waiting time of metro when a person reaches metro station.
 - v) Monthly income of the family.
8. (a) Write any 10 principles of data visualisation.
- (b) What is the relation of unit on y-axis with unit on x-axis in histogram. (5+5)

TUTOR MARKED ASSIGNMENT

MST-002: Descriptive Statistics

Course Code: MST-002

Assignment Code: MST-002/TMA/2025

Maximum Marks: 100

Note: All questions are compulsory. Answer in your own words.

1. State whether the following statements are true or false and also give the reason in support of your answer: (5×2=10)

(a) If $X_1, X_2, X_3, \dots, X_n$ and $Y_1, Y_2, Y_3, \dots, Y_n$ are the variate values of two variables X and Y, and their geometric means are G_1 and G_2 , respectively, then geometric mean of $(x_j/y_i); i = 1, 2, \dots, n$ will be (G_1/G_2) .

(b) If X and Y are two independent variables and the variables $U = X + Y$ and $V = X - Y$, then the

$$r(U, V) = \frac{\sigma_X^2 - \sigma_Y^2}{\sigma_X^2 + \sigma_Y^2}$$

(c) If each value of X is divided by 2 and of Y is multiplied by 2, then b'_{YX} will be same as b_{YX} .

(d) The mean and standard deviation of a set of values are 25 and 5, respectively. If a constant value 5 is added to each value, the coefficient of variation of the new set of values is equal to 10%.

(e) If $(A) = 90$, $(AB) = 40$, $N = 150$ and $(\beta) = 80$ then $(\alpha\beta) = 30$.

2. (a) The numbers 3.2, 5.8, 7.9 and 4.5 have frequencies Y, (Y + 2), (Y - 3) and (Y + 6), respectively. If the arithmetic mean is 4.876, find the value of Y and write the whole series. (6)

(b) The following is the distribution of age (in years) of 800 workers:

Age Group	No. of Workers
20 — 25	50
25 — 30	70
30 — 35	100
35 — 40	180
40 — 45	150
45 — 50	120
50 — 55	70
55 — 60	60

Find (i) Median, (ii) Quartile Deviation, and (iii) Coefficient of Quartile Deviation.

(10)

3. (a) The value of Spearman's rank correlation coefficient of a set of non-repeating values was found to be $2/3$. The sum of the squares of difference between the corresponding ranks was 55. Find the number of pairs. (6)

- (b) Calculate Karl Pearson's coefficient of correlation between X and Y for the following data:

$$N = 12, \sum X = 120, \sum Y = 130, \sum X^2 = 150, \sum Y^2 = 200 \text{ and } \sum XY = 1050 \quad (8)$$

4. (a) The following table shows the information as:

Statistical Measures	Advertisement Expenditure (X) (Rs. Lakhs)	Sales (Y) (Rs Lakhs)
Mean	20	100
Standard Deviation	03	12

$r(X, Y) = 0.8$. Then find

- (i) the expected advertising expenditure of the company if sale is Rs. 125 lakhs, and
(ii) the expected sales of the company if the advertising expenditure is Rs 32 lakhs. (8)

- (b) Given the following data:

$$r_{12} = 0.8, r_{13} = 0.6 \text{ and } r_{23} = 0.4 \text{ then find (i) } r_{12.3} \text{ (ii) } r_{13.2} \text{ (iii) } r_{23.1} \text{ (iv) } R_{1.23} \quad (4)$$

5. (a) An investigation of 23713 households was made in an urban and rural mixed locality. Of these 1618 were farmers, 2015 well to do and 770 families were having at least one graduate. Of these graduate families 335 were those of farmers and 428 were well to do; also 587 well to do families were those of farmers and out of them only 156 were having at least one graduate. Obtain all the ultimate class frequencies. (6)

- (b) Can vaccination be regarded as a preventive measure for smallpox from the given data:

- (i) Of 1482 persons in a locality exposed to smallpox, 368 in all were attacked, and
(ii) Of 1482 persons, 343 had been vaccinated and of these only 35 were attacked. (6)

6. (a) In a statistical study relating to the prices (in T) of two shares, X and Y, the following two regression lines were found as $8X - 10Y + 70 = 0$ and $20X - 9Y - 65 = 0$. The standard deviation of X = 3, then find (i) the values of X and Y, (ii) $r(X, Y)$, and (iii) standard deviation of Y. (12)

- (b) Suppose X and Y are the two variables having the correlation coefficient 0.85. The following are the values they have:

X	Y
10	40
30	30
50	70
60	80

If two new variables X' and Y' are obtained by adding 50 to each value of X and 100 to each value of Y, respectively, calculate the correlation coefficient between X' and Y' using the above data. Also compare the results. (8)

7. (a) 50% of items have characteristics A and B both, 35% have A, but not B, 25% have B but not A. Show that there must be some misprints in this report. (6)
- (b) In the given data, two frequencies are missing and its mean is found to be 1.46.

No. of Accidents (x)	Frequencies (f)
0	46
1	?
2	?
3	25
4	10
5	5
Total	200

Find the missing frequencies.

(10)

TUTOR MARKED ASSIGNMENT

MST-003: Probability Theory

Course Code: MST-003

Assignment Code: MST-003/TMA/2025

Maximum Marks: 100

Note: All questions are compulsory. Answer in your own words.

1. State whether the following statements are **True** or **False** and also give the reason in support of your answer. (5×2=10)
 - (a) Sample space of a (i) random experiment tossing two coins simultaneously and (ii) One coin two times is the same.
 - (b) Standard deviation of a random variable X may take any real value, i.e. its value lies in the interval $(-\infty, \infty)$.
 - (c) If events $E_1, E_2, E_3, E_4, \dots, E_n$ are mutually exclusive and exhaustive then $P(E_1 \cup E_2 \cup E_3 \cup \dots \cup E_n)$ will be greater than 1/2 but less than 1.
 - (d) If S is sample space of a random experiment and E is an event defined on this sample space then $P(S|E) = 1$.
 - (e) If X is a random variable having range set $\{0, 1, 2, 3\}$ then the set $\{x \in S : X(x) \geq 0\}$ is an event having at least one outcome of the random experiment.

2. There are 4 black, 3 blue and 8 red balls in an urn. Three balls are selected one by one without replacement. What is the probability that:

- (i) First ball drawn is black, second one is red and third one is blue
- (ii) All the three balls are of the same colour. (5+5)

3. A random 5-card poker hand is dealt from a standard deck of cards. Find the probability (in terms of binomial coefficients) of getting a flush (all 5 cards being of the same suit: do not count a royal flush, which is a flush with an ace, king, queen, jack and 10). (10)

4. Show that

$$f(x) = \begin{cases} \frac{1}{2} \left(\frac{1}{2}\right)^{x-1} & x = 1, 2, 3, 4, 5, \dots \\ 0 & \text{otherwise} \end{cases}$$

is a valid PMF for a discrete random variable. Also find out its CDF. (10)

5. A group of 100 people are comparing their birthdays (as usual, assume their birthdays are independent and not on February 29, etc.). Find the expected number of pairs of people with the same birthday, and the expected number of days in the year on which at least two of these people were born. (10)

6. Random variable X follows Beta distribution with parameters $a = 3, b = 2$ and has pdf

$$f(x) = \begin{cases} \frac{1}{2} 2^x (1-x)^2, & 0 < x < 1 \\ 0, & \text{otherwise} \end{cases}$$

Find (i) CDF of X (ii) $P[0 < X < 1/2]$ (iii) mean and variance of X without using direct formula for mean and variance. (10)

7. Consider the joint PDF for the type of customer service X ($0 =$ telephonic hotline, $1 =$ Email) and of satisfaction score Y ($1 =$ unsatisfied, $2 =$ satisfied, $3 =$ very satisfied):

	Y		
X	1	2	3
0	0	$1/2$	$1/4$
1	$1/6$	$1/12$	0

- (a) Determine and interpret the marginal distributions of both X and Y .
- (b) Calculate the 75 % quantile for the marginal distribution of Y .
- (c) Determine and interpret the conditional distribution of satisfaction level for $X = 1$.
- (d) Are the two variables independent?
- (e) Calculate and interpret the covariance of X and Y . (20)
8. State Monty Hall problem and solve it. (20)

TUTOR MARKED ASSIGNMENT

MST-004: Statistical Inference

Course Code: MST-004

Assignment Code: MST-004/TMA/2025

Maximum Marks: 100

Note: All questions are compulsory. Answer in your own words.

1. State whether the following statements are **True** or **False**. Give reason in support of your answer: (5×2=10)
 - (a) If the probability of non rejection of H_0 when H_1 is true is 0.4 then power of the test will be 0.6.
 - (b) If T_1 and T_2 are two estimators of the parameter θ such that $\text{Var}(T_1) = 1/n$ and $\text{Var}(T_2) = n$ then T_1 is more efficient than T_2 .
 - (c) A 95% confidence interval is smaller than 99% confidence interval.
 - (d) If the level of significance is the same, the area of the rejection region in a two-tailed test is less than that in a one-tailed test.
 - (e) Non parametric tests are more powerful than the parametric tests.
2. If a finite population has four elements: 6, 1, 3, 2.
 - (a) How many different samples of size $n = 2$ can be selected from this population if you sample without replacement?
 - (b) List all possible samples of size $n = 2$.
 - (c) Compute the sample mean for each of the samples given in part *b*.
 - (d) Find the sampling distribution of \bar{x} and draw the histogram.
 - (e) Compute standard error.
 - (f) If all four population values are equally likely, calculate the value of the population mean μ . Do any of the samples listed in part (b) produce a value of \bar{x} exactly equal to μ ? (13)
3. A study was conducted to compare the mean numbers of police emergency calls per 8-hour shift in two districts of a large city. Samples of 100 8-hour shifts were randomly selected from the police records for each of the two regions and the number of emergency calls was recorded for each shift. The sample statistics are listed here:

	Region	
	1	2
Sample size	100	100
Sample mean	2.4	3.1
Sample variance	1.44	2.64

Find a 90% confidence interval for the difference in the mean numbers of police emergency calls per shift between the two districts of the city. Interpret the interval. (7)

4. A bond proposal for school construction will be submitted to the voters at the next municipal election. A major portion of the money derived from this bond issue will be used to build schools in a rapidly developing section of the city, and the remainder will be used to renovate and update school buildings in the rest of the city. To assess the viability of the bond proposal, a random sample of $n_1 = 50$ residents in the developing section and $n_2 = 100$ residents from the other parts of the city were asked whether they plan to vote for the proposal. The results are tabulated below

Sample Values for Opinion on Bond Proposal

	Developing Section	Rest of the City
Sample size	50	100
Number favoring proposal	38	65

- (a) Estimate the difference in the true proportions favoring the bond proposal with a 99% confidence interval.
- (b) If both samples were pooled into one sample of size $n = 150$, with 103 in favor of the proposal, provide a point estimate of the proportion of city residents who will vote for the bond proposal. **(10)**
5. The following data relate to the number of items produced per shift by two workers for a number of days:

Worker A	19	22	24	27	24	18	20	19	25	
Worker B	26	37	40	35	30	40	26	30	35	45

Can it be inferred that Worker A is more stable worker compared to B by testing the variation in the item produced by them at 5% level of significance. **(10)**

6. If magnitude of earthquakes recorded in a region of a country follows a distribution with parameter μ whose pdf is given below:

$$f(x) = \frac{1}{\sigma\sqrt{2\pi}} e^{-\frac{1}{2}\left(\frac{x-\mu}{\sigma}\right)^2}, \quad -\infty < x < \infty$$

then show that the estimators of the parameter μ using maximum likelihood and method of moments are same. **(15)**

7. A company plans to promote a new product by using one of three advertising campaigns. To investigate the extent of product recognition from these three campaigns, 15 market areas were selected and five were randomly assigned to each advertising plan. At the end of the ad campaigns, random samples of 400 adults were selected in each area and the proportions who were familiar with new product were recorded. The responses were not approximately normal. Is there a significant difference among the three population distributions from which these samples came? Use an appropriate nonparametric method to answer this question at 5% level of significance.

Campaign		
1	2	3
0.33	0.28	0.21
0.29	0.41	0.30

0.21	0.34	0.26
0.32	0.39	0.33
0.25	0.27	0.31

(15)

8. A psychology class performed an experiment to determine whether a recall score in which instructions to form images of 25 words were given differs from an initial recall score for which no imagery instructions were given. Twenty students participated in the experiment with the results listed in the table:

Student	With Imagery	Without Imagery	Student	With Imagery	Without Imagery
1	20	5	11	17	8
2	24	9	12	20	16
3	20	5	13	20	10
4	18	9	14	16	12
5	22	6	15	24	7
6	19	11	16	22	9
7	20	8	17	25	21
8	19	11	18	21	14
9	17	7	19	19	12
10	21	9	20	23	13

- (a) What two testing procedures can be used to test for differences in the distribution of recall scores with and without imagery? What assumptions are required for the parametric procedure? Do these data satisfy these assumptions?
- (b) Use both the parametric and non-parametric tests for differences in the distributions of recall scores under these two conditions.
- (c) Compare the results of the tests in part b. Are the conclusions for same? If not, why not?

(20)

TUTOR MARKED ASSIGNMENT

MST-005: Statistical Techniques

Course Code: MST-005

Assignment Code: MST-005/TMA/2025

Maximum Marks: 100

Note: All questions are compulsory. Answer in your own words.

1. State whether the following statements are true or false and also give the reason in support of your answer: (2×5=10)

- (a) The total number of all possible samples of size 2 without replacement from a population of size 7 is 21.
- (b) Consecutive 3 random numbers starting from 8937 by 'middle square method' are 8937, 8699, 6726.
- (c) RBD is suitable in situations where it is not possible to divide the experimental material into a number of homogeneous blocks.
- (d) As we increase the sample size, representativeness of the population by the sample decreases.
- (e) In a big hall, there are 50 rows and each row has 60 students. A research scholar selects 10 rows randomly and then randomly selects 15 students from each selected row. It is an example of cluster sampling procedure.

2. (a) Draw all possible samples of size 2 from the population [2, 3, 4] and verify that

$$E(\bar{x}) = \bar{X} \quad \text{Also find variance of } \bar{x} \quad (10)$$

- (b) A sample of 60 students is to be drawn from a population consisting of 600 students belonging to two villages, A and B. The means and standard deviations of their marks are give below:

Villages	Stratum sizes (N_i)	Means (x_i)	Standard deviations
Village A	400	60	20
Village B	200	120	80

What are the sample sizes for the two villages using proportional allocation technique?

(6)

3. To determine the yield rate of wheat in a district of Punjab, 6 groups of 6 plots each were constructed. The data are given in the following table:

Plot No.	Group 1	Group 2	Group 3	Group 4	Group 5	Group 6
1	8	6	18	13	17	12
2	13	5	8	7	15	15
3	11	16	6	13	10	11
4	26	5	10	6	21	17
5	13	16	16	7	20	8
6	31	5	20	2	25	10

Select a cluster sample of 3 clusters from the above data and find its sample mean. Further, explain the procedure of two-stage sampling if we want to draw a sample of 6 plots. Which are the 6 plots in your sample? (7)

4. The following data relate to production in kg of three varieties P, Q, R of wheat:

P : 14 16 18
 Q : 14 13 15 22
 R : 18 16 19 15 20

Is there any significant difference among the three varieties at 5% level of significance? (7)

5. A researcher wants to test four diets A, B, C, D on growth rate in mice. These animals are divided into 3 groups according to their weights. Heaviest 4, next 4 and lightest 4 are put in Block I, Block II, and Block III, respectively. Within each block, one of the diets is given at random to the animals. After 15 days, increase in weight is noted, which is given in the following table:

Blocks	Treatments/Diets			
	A	B	C	D
I	12	8	6	5
II	15	12	9	6
III	14	10	8	5

Perform a two-way ANOVA to test whether the data indicates any significant difference between the four diets due to different blocks. (10)

6. In the following data, two values are missing. Estimate these values by Yates method and analyse the data by suitable technique.

Treatments	Blocks		
	I	II	III
A	12	14	12
B	10	y	8
C	x	15	10

(12)

7. Identify the design given in the following table and then carry out the analysis:

Column	Row			
	I	II	III	IV
I	A 8	C 18	B 11	D 8
II	C 16	B 10	D 7	A 4
III	B 12	D 10	A 6	C 20
IV	D 10	A 9	C 28	B 16

(14)

8. (a) The distribution function of Pareto distribution is given by

$$f(x) = \frac{k}{x^{k+1}}, \quad a > 0, 0 < k \leq x.$$

Given a $U \sim U(0, 1)$, generate a random number from the above distribution, when $a = 2$ and $k = 1$. Suppose $U = 0.5$, then find x . (4)

(b) Generate a complete cycle for the LCG given below: ~~$x_{i+1} = 5x_i \pmod{16}$~~ , with $x_0 = 5$. A man tosses an unbiased coin ten times. Using the first ten random numbers generated above, obtain a sequence of heads and tails by taking Head (H) as $u \geq 0.5$. (10)

9. Times between successive crashes of a computer system were generated for a 6-month period and are given in increasing order as follows (time in hours):

1	10	20	30	40	52	63	70	80	90	100	102
130	140	190	210	266	310	530	590	640	1340		

The parameter $a = 0.00435$, mean = $1/a = 230$ hrs.

Use the Kolmogorov-Smirnov test to examine the goodness of fit of exponential distribution. (10)

TUTOR MARKED ASSIGNMENT

MSTE-001: Industrial Statistics-I

Course Code: MSTE-001

Assignment Code: MSTE-001/TMA/2025

Maximum Marks: 100

Note: All questions are compulsory. Answer in your own words.

1. State whether the following statements are **True** or **False**. Give reason in support of your answer: **(5×2=10)**
 - (a) Statistical quality control (SQC) is a technique of process control only.
 - (b) Twenty pieces of different length of cloth contained 2, 4, 1, 3, 5, 4, 2, 7, 3, 5, 2, 2, 4, 5, 6, 4, 2, 1, 2, 4 defects respectively. To check the process is under control with respect to the number of defects, we should use np-chart.
 - (c) If the probabilities are not associated with the occurrence of different states of nature, then the situation is known as decision making under risk.
 - (d) In single sampling plan, if we increase acceptance number then the OC curve will be steeper.
 - (e) A system has four components connected in parallel configuration with reliability 0.2, 0.4, 0.5, 0.8. To improve the reliability of the system most, we have to replace the component which reliability is 0.2.
2. Twenty samples each of size 10 were inspected. The number of defectives detected in each of them is given below: 0, 1, 0, 3, 9, 2, 0, 7, 0, 1, 1, 0, 0, 3, 1, 0, 0, 2, 1, 0 Find the control limits for the number of defectives and establish quality standards for the future. Plot the graph and interpret. **(10)**
3. A manufacturer of men's jeans purchases zippers in lots of 500. The jeans manufacturer uses single-sample acceptance sampling with a sample size of 10 to determine whether to accept the lot. The manufacturer uses $c = 2$ as the acceptance number. Suppose 3% nonconforming zippers are acceptable to the manufacturer and 8% nonconforming zippers are not acceptable. Let incoming quality be 4%.
 - i) Construct an OC curve.
 - ii) Average outgoing quality (AOQ), if the rejected lots are screened and all defective zippers are replaced by non-defectives.
 - iii) Average total inspection (ATI). **(6+2+2)**
4. An office supply company ordered a lot of 400 printers. When the lot arrives the company inspector will randomly inspect 12 printers. If more than three printers in the sample are non-conforming, the lot will be rejected. If fewer than two printers are non-conforming, the lot will be accepted. Otherwise, a second sample of size 8 will be taken. Suppose the inspector finds two non-conforming printers in the first sample and two in the second sample. Also AQL and LTPD are 0.05 and 0.10 respectively. Let incoming quality be 4%.
 - i) What is the probability of accepting the lot at the first sample?
 - ii) What is the probability of accepting the lot at the second sample?
 - iii) Find AQL and ATI **(15)**

5. A two-person zero-sum game having the following payoff matrix for player A

		Player B				
		I	II	III	IV	V
Player A	I	2	4	3	8	4
	II	5	6	3	7	8
	III	6	7	9	8	7
	IV	4	2	8	4	3

- (i) Check whether saddle point exist or not.
(ii) If saddle point does not exist then determine optimal strategies for both the manufacturers and value of the game. (2+8)
6. A system has seven independent components and reliability block diagram of it shown blow:

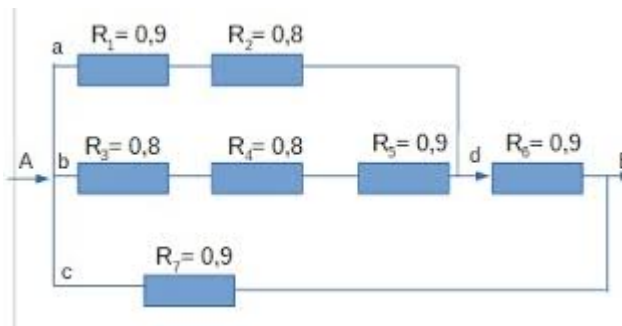

- Find reliability of the system. (10)
7. The failure data for 40 electronic components is shown below:

Operating Time (in hours)	0-5	5-10	10-15	15-20	20-25	25-30
Number of Failures	5	7	6	4	5	4
Operating Time (in hours)	30-35	35-40	40-45	45-50	≥50	
Number of Failures	4	0	2	1	2	

- Estimate the reliability, cumulative failure distribution, failure density and failure rate functions. (15)
8. At a call centre, callers have to wait till an operator is ready to take their call. To monitor this process, 5 calls were recorded every hour for the 8-hour working day. The data below shows the waiting time in seconds:

Time	Sample Number				
	1	2	3	4	5
9 a.m	8	9	15	4	11
10	7	10	7	6	8
11	11	12	10	9	10
12	12	8	6	9	12

1 p.m.	11	10	6	14	11
2	7	7	10	4	11
3	10	7	4	10	10
4	8	11	11	11	7

- i) Use the data to construct control charts for mean and variability and comments about the process. If process is out of control, then calculate the revised control limits.
- ii) If the specification limits as the 8 ± 2 , then find the process capability. Does it appear that the process is capable of meeting the specification requirements?

(20)

TUTOR MARKED ASSIGNMENT

MSTE-002: Industrial Statistics-II

Course Code: MSTE-002

Assignment Code: MSTE-002/TMA/2025

Maximum Marks: 100

Note: All questions are compulsory. Answer in your own words.

1. State whether the following statements are **True** or **False**. Give reasons in support of your answers. (5x2=10)
 - (a) The solution of a transportation problem with 5 rows (supplies) and 4 columns (destinations) is feasible if number of possible allocations are 8.
 - (b) The moving averages of suitable period in a time-series are free from the influences of seasonal and cyclic variations.
 - (c) If the basic solutions for a system of equations are (- 2, 0, 1), (0, 1, 3), (- 2, 3, 0), then only (0, 1, 3) is feasible.
 - (d) In the stepwise selection method of multiple regression model, once a variable enters in the model then it always remains in the model.
 - (e) An enterprise requires 1000 units per month. The ordering cost is estimated to be 50 per order. The purchase price is 20 per unit and the carrying cost per unit is 10% of it. Then the economic lot size to be ordered is 775.

2. Use the penalty (Big M) method to solve the following LP problem: (12)

$$\text{Minimise } Z = 5x_1 + 3x_2$$

Subject to the constraints:

$$2x_1 + 4x_2 \leq 12$$

$$2x_1 + 2x_2 = 10$$

$$5x_1 + 2x_2 \geq 10$$

$$x_1, x_2 \geq 0.$$

3. A company has three production facilities S_1 , S_2 and S_3 with production capacity of 7, 9 and 18 units (in 100s) per week of a product, respectively. These units are to be shipped to four warehouses D_1 , D_2 , D_3 and D_4 with requirement of 5, 6, 7 and 14 units (in 100s) per week, respectively. The transportation costs (in Rs) per unit between factories to warehouses are given in the table below:

	D₁	D₂	D₃	D₄	Capacity
S₁	19	30	50	10	7
S₂	70	30	40	60	9
S₃	40	8	70	20	18
Demand	5	8	7	14	34

Obtain optimal solution by the MODI method.

(12)

4. Four professors are capable of teaching any one of four different courses. Class preparation time in hours for different topics varies from professor to professor and is given in the table below:

Professor	A	B	C	D
Linear Programming	2	15	13	4
Queuing Theory	10	4	14	15
Transportation Problem	9	14	16	13
Regression Analysis	7	8	11	9

Each professor is assigned only one course. Determine an assignment schedule so as to minimise the total course preparation time for all courses. **(10)**

5. In a railway marshalling yard, goods trains arrive at a rate of 36 trains per day. Assuming that the inter-arrival and service time distributions both follow exponential distribution with an average of 30 minutes, calculate the following:

- (i) Traffic intensity
- (ii) The mean queue length
- (iii) Probability that the queue size exceeds **(8)**

6. Using the graphical method to minimise the time required to process Job 1 and Job 2 on five machines A, B, C, D and E, find the minimum elapsed times and idle times to complete both jobs.

Job 1	Sequence	A	B	C	D	E
	Time (in hours)	1	2	3	5	4
Job 2	Sequence	C	A	D	E	B
	Time (in hours)	3	4	2	1	5

(8)

7. A firm wants to know whether there is any linear relationship between the sales (X) and its yearly revenue (Y). The records for 10 years were examined and the following results were obtained:

$$\sum X=265, \sum Y=27.73, S_{XX}=285.6, S_{YY}=6.978, \text{ and } S_{XY}=57.456.$$

- (a) Fit a regression line taking Y as the dependent variable and X as the independent variable.
 - (b) Test whether the sales have any effect on revenue at 5% level of significance.
 - (c) Comment on the goodness of fit of the regression line. **(2+3+5)**
8. A researcher is interested in developing a linear model for the electricity consumption of a household having an AC (1.5 ton) so that she can predict the electricity consumption. For this purpose, she selects 25 houses and records the electricity consumption (in kWh), size of house (in square feet) and AC hours for one month during summers. The results obtained are:

$$SS(B_0) = 12526.08, SS(B_0, B_1) = 17908.47, SS(B_0, B_2) = 17125.23, SS(B_0, B_1, B_2) = 18079.0,$$

$$\hat{B}_0=22.38, \hat{B}_1=1.6161, \hat{B}_2=0.0144, \hat{\sigma}^2=10.53, SE(\hat{B}_0)=0.17, \text{ and } SE(\hat{B}_2)=0.0035.$$

Build a regression model by selecting appropriate regressors in the model using the Stepwise Selection method. **(10)**

9. The following table represents the sales (in thousands) of mobile sets of a shop for 16 quarters over four years:

Year	Quarter			
	Q ₁	Q ₂	Q ₃	Q ₄
2011	554	590	616	653
2012	472	501	521	552
2013	501	531	553	595
2014	403	448	460	480

- (a) Compute the seasonal indices for four quarters by Simple average method.
(b) Obtain deseasonalised values. **(10)**
10. Seven successive observations on a stationary time-series are as follows:
12, 14, 13, 10, 15, 12, 15
- (a) Calculate auto-covariances C_0, C_1, C_2, C_3 and C_4 .
(b) Calculate auto-correlation coefficients r_1, r_2, r_3 and r_4 .
(c) Plot the correlogram. **(10)**

TUTOR MARKED ASSIGNMENT

MSTE-003: Biostatistics-I

Course Code: MSTE-003

Assignment Code: MSTE-003/TMA/2022

Maximum Marks: 100

Note: All questions are compulsory. Answer in your own words.

1. State whether the following statements are **True** or **False**. Give reason in support of your answer: (2×5=10)
 - (a) Suppose A is the exposure and B is a confounding factor for outcome C, then there will be a path from A to C via B.
 - (b) Doing exercise may also be a regimen.
 - (c) In clinical trials, a control only may be: treatment or no treatment.
 - (d) In Greville's method, the central death rate is more in the life table than the population.
 - (e) In a slope ratio assay, both regression lines have common slope.
2. Explain with examples:
 - (a) Various sources of demographic data in India
 - (b) Types of bioassays
 - (c) LD50 and ED50 (5+5+5)
3.
 - (a) Differentiate between complete and abridged life tables.
 - (b) The data on population and number of deaths for different age groups of Districts A and B in the year 2001 were collected in the following table:

Age Group (Years)	District A		District B	
	Population	No. of Deaths	Population	No. of Deaths
0 - 5	55,300	385	51,165	805
5 - 15	109,125	410	98,170	510
15-35	1,72,050	675	1,68,450	790
35-50	1,15,600	1625	1,40,625	990
50 & above	2,65,775	3288	2,40,900	2485

Calculate standardised death rate by direct method, taking population of District A as the standard population. (5+5)

4. In a parallel-line assay, total 18 guinea pigs, 4 guinea pigs each from 3 different breeds were selected and classified into 4 groups for each breed. Two groups were administered with two doses of the standard preparation and remaining two groups with two doses of the test preparation. The responses of these doses are recorded in the following table:

Breed	Dose (Standard)			Dose (Test)		
	10 (in µL)	15 (in µL)	20 (in µL)	5 (in µL)	10 (in µL)	15 (in µL)

1	25	42	55	20	43	64
2	23	47	52	23	42	66
3	22	38	58	24	44	67

- (i) Determine the dose-response regression models for both preparations.
- (ii) Test whether the dose-response curves of both preparations are linear and parallel to each other or not.
- (iii) Interpret whether the relative potency and its confidence interval can be computed or not. (8+15+2)

5(a) If D^+ and D^- denote presence and absence, respectively, of a disease and T^+ and T^- denote test result as positive and negative, respectively, then on the basis of the following information:

	D^+	D^-	Total
T^+	145	2000	2145
T^-	15	48000	48015
Total	160	50000	50160

Find: (i) sensitivity (ii) specificity (iii) positive and negative predictive values.

(b) Obtain sample size for the following given information:

~~$0.04, 0.72, 0.84, 0.01, 0.25$~~

(5+5)

6.(a) Explain design and analysis of data of case control study in detail.

(b) Creatinine excretion is a parameter of kidney function. Generally speaking, lower values indicate better health. This depends on body weight. A researcher conducted a study on creatinine excretion in test group and control group to find the efficacy of a new drug. The subjects were randomly divided. He included 100 subjects in each group but for this exercise consider only 10 subjects in each group. The data obtained on creatinine level in these 10 subjects are as follows:

Test group: 16.6 19.8 17.1 17.0 15.6 20.3 24.7 18.5 17.6 22.0

Control group: 23.2 22.0 21.9 16.7 14.2 23.2 24.8 25.5 28.1 21.8

Do you think that creatinine excretion was really lower in the test group on average?

(15+5)

7. Suppose you try a regimen A on 1000 subjects and regimen B on 1600 subjects. Results of the trial show that efficacies of regimen A and B are 76% and 82% respectively. Suppose doctor determines 4% as superiority margin. Can you consider regimen B as superior to regimen A. (10)

TUTOR MARKED ASSIGNMENT

MSTE-004: Biostatistics-II

Course Code: MSTE-004

Assignment Code: MSTE-004/TMA/2022

Maximum Marks: 100

Note: All questions are compulsory. Answer in your own words.

1. State whether the following statements are **True** or **False**. Give reason in support of your answer: (2×5=10)

(a) The value of sensitivity of the following results of a diagnostic test is 0.85.

Disease	Test result		Total
	+	-	
Present	170	30	200
Absent	20	280	300

(b) For the following cohort study, the relative risk for the lung cancer among smokers is 3.5.

	Lung Cancer	No Lung Cancer	Total
Smokers	100	1220	1320
Non-smokers	50	2260	2310

(c) The logit link function is $\text{logit}(\pi) = \ln\left(\frac{\pi}{1-\pi}\right)$.

(d) We define three indicator/dummy variables for a regressor variable with three categories.

(e) Left censoring occurs whenever the exact time of occurrence of an event is not known.

2. Differentiate between Chi-square tests for association and homogeneity of proportions. Also mention the assumptions of these tests. (10)

3. A random sample of 250 patients was selected and their workout timing and diabetes status were recorded. The following table shows the workout timing and severity of diabetes:

Workout (in minutes)	Severity of diabetes status		
	Low	Moderate	High
0 –15	06	27	19
15 to 30	08	36	17
30 to 45	21	45	33
≥ 45	14	18	06

Test at 5% level of significance whether workout habit and diabetes are associated with to each other or not. (10)

4. (a) Explain the assumptions underlying multiple linear regression model.
(b) Suppose a researcher wants to evaluate the effect of cholesterol on the blood pressure. The following data on serum cholesterol (in mg/dL) and systolic blood pressure (in

mm/Hg) were obtained for 15 patients to explore the relationship between cholesterol and blood pressure:

S. No.	Cholesterol (mg/dL)	SBP (mm/Hg)
1	300	150
2	410	270
3	380	210
4	530	310
5	570	350
6	490	310
7	340	210
8	320	150
9	280	110
10	550	320
11	340	220
12	350	170
13	410	260
14	390	230
15	450	270

- (i) Fit a linear regression model using the method of least squares.
- (ii) Construct the normal probability plot for the data on serum cholesterol and systolic blood pressure.
- (iii) Test the significance of the fitted regression model. (5+15)

5. Write a short note on the following:

- (i) Polytomous logistic models
- (ii) Poisson regression
- (iii) Kaplan and Meier method (12)

6. The following data on diagnosis of coronary heart disease (where 0 indicating absence and 1 indicating presence), serum cholesterol (in mg/dl), resting blood pressure (in mmHg) and weight (in kg) were obtained for 80 patients to explore the relationship of coronary heart disease with cholesterol and weight.

S. No.	Serum Cholesterol (mg/dl)	Weight (kg)	Number of Patients having CHD	Total Number of Patients
1	420	60	10	20
2	450	68	15	30
3	400	54	4	15

4	510	74	2	10
5	480	62	1	5

- (i) Fit a multiple logistic model for the dependence of coronary heart disease on the average serum cholesterol and weight considering

~~0.4, 0.2, 0.35, 0.172~~ as the initial values of the parameters (solve only for one Iteration).

- (ii) Test the significance of the fitted model using Hosmer-Lemeshow test at 5% level of significance. **(12+8)**

7.(a) Describe censoring and differentiate between different types of censoring with the help of examples which are not considered in Block 4 of MSTE-004.

- (b) A study was conducted on 185 patients aged more than 45 years which are followed until the time of death or up to 10 years, whichever comes first. The patients have different covariates: age, gender (male/female), systolic blood pressure, smoking (yes/no), total serum cholesterol and diabetes (yes/no). The objective of this study is to determine which covariate influences the survival time. An analysis is conducted to investigate differences in all-cause mortality between men and women participating in the study. Suppose we obtain the following results after applying the Cox regression hazard model analyses:

Risk Factor	Parameter Estimate	SE
Age	0.150	0.010
Gender	0.450	0.150
Systolic Blood Pressure	0.015	0.008
Smoking	0.650	0.170
Total Serum Cholesterol	0.002	0.004
Diabetes	-0.350	0.250

- (i) Obtain hazard ratio and interpret the results.
(ii) Find the 99% confidence interval for the hazard ratio.
(iii) Test whether the covariates are significant or not at 1% level of significance.

(8+10)